

MF 4

Drawing# 051130-1b

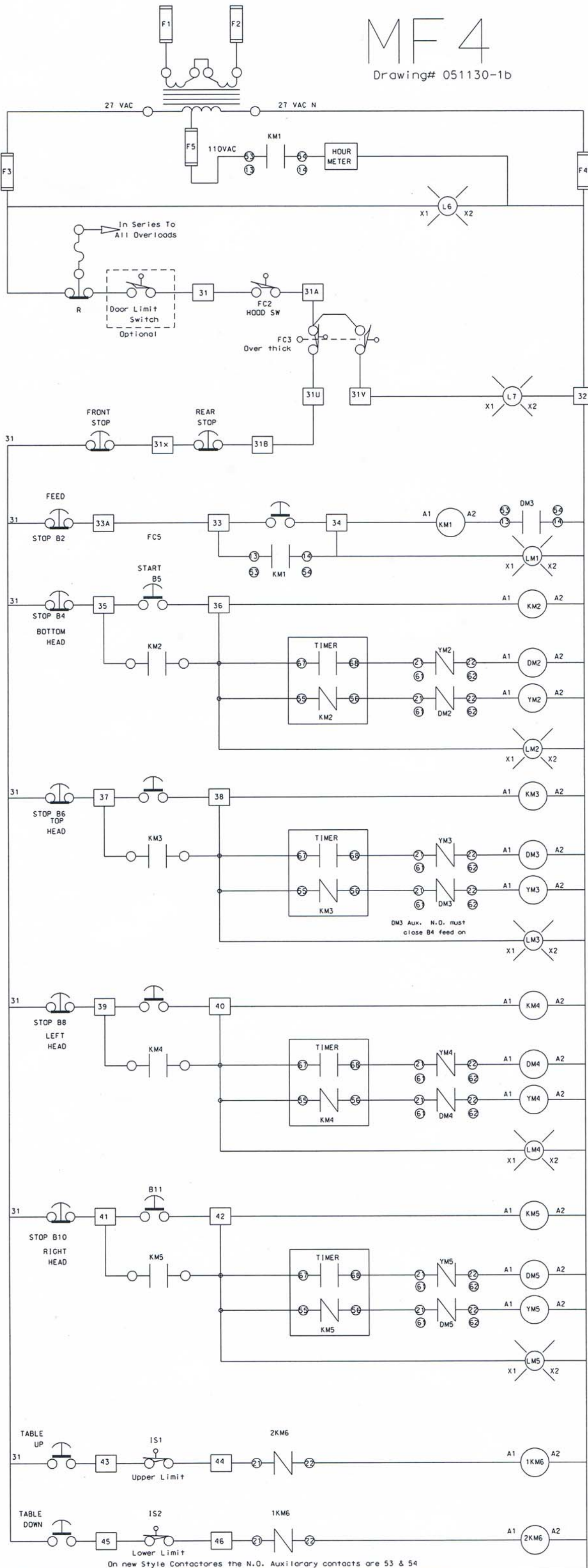

On new Style Contactors the N.O. Auxiliary contacts are 53 & 54

Index to MF Wiring Diagram (12/23/02)

FUSES

- F1 FUSE PRIMARY/TRANSFORMER
- F2 FUSE PRIMARY/TRANSFORMER
- F3 FUSE SECONDARY/TRANSFORMER
- F4 FUSE SECONDARY/TRANSFORMER
- F5 FUSE HOUR METER
- FM1 FEED MOTOR FUSES (3)
- FM2 BOTTOM HEAD MOTOR FUSES (3)
- FM3 TOP HEAD MOTOR FUSES (3)
- FM4 LEFT SIDE HEAD MOTOR FUSES (3)
- FM5 RIGHT HEAD MOTOR FUSES (3)
- FM6 POWERED TABLE MOTOR FUSES (3)
- FM7 GANG SAW MOTOR FUSES (3)

START/STOP SWITCHES

- RSTOP REAR E-STOP SWITCH
- FSTOP FRONT E-STOP SWITCH
- B2 FEED STOP SWITCH
- B3 FEED START SWITCH
- B4 BOTTOM HEAD MOTOR SWITCH
- B5 BOTTOM HEAD MOTOR SWITCH
- B6 TOP HEAD MOTOR SWITCH
- B7 TOPHEAD MOTOR SWITCH
- B8 LEFT SIDE HEAD MOTOR SWITCH
- B9 LEFT SIDE HEAD MOTOR SWITCH
- B10 RIGHT SIDE HEAD MOTOR SWITCH
- B11 RIGHT SIDE HEAD MOTOR SWITCH
- B12 TABLE UP SWITCH
- B13 TABLE DOWN SWITCH
- B14 GANG SAW SWITCH
- B15 GANG SAW SWITCH

LIMIT SWITCHES

- FC1 DOOR LIMIT SWITCH
- FC2 MAIN COVER LIMIT SWITCH
- FC3 FEED SYSTEM LIMIT SWITCH
- FC4 ARBOR COVER LIMIT SWITCH
- FC5 OUTFEED ROLL LIMIT SWITCH
- IS1 TABLE UP LIMIT SWITCH
- IS2 TABLE DOWN LIMIT SWITCH

LIGHTS

- L6 MAIN ENCLOSURE LIGHT
- L7 OVERSIZE LUMBER LIGHT
- LM1 FEED MOTOR LIGHT
- LM2 BOTTOM HEAD MOTOR LIGHT
- LM3 TOP HEAD MOTOR LIGHT
- LM4 LEFT SIDE HEAD MOTOR LIGHT
- LM5 RIGHT SIDE HEAD MOTOR LIGHT
- LM7 GANG SAW MOTOR LIGHT

OVERLOADS

- R DESIGNATES OVERLOADS
- RM1 FEED MOTOR OVERLOAD
- RM2 BOTTOM HEAD MOTOR OVERLOAD
- RM3 TOP HEAD MOTOR OVERLOAD
- RM4 LEFT SIDE HEAD MOTOR OVERLOAD
- RM5 RIGHT SIDE HEAD MOTOR OVERLOAD
- RM6 TABLE UP/DOWN MOTOR OVERLOAD
- RM7 GANG SAW MOTOR OVERLOAD

MOTORS

- M1 FEED MOTOR
- M2 BOTTOM HEAD MOTOR
- M3 TOP HEAD MOTOR
- M4 LEFT SIDE HEAD MOTOR
- M5 RIGHT SIDE HEAD MOTOR
- M6 TABLE UP/DOWN MOTOR
- M7 GANG SAW MOTOR

MOTOR CONTACTORS

- KM1 FEED MOTOR CONTACTOR
- KM2 BOTTOM HEAD MOTOR (RUN CIRCUIT)
- DM2 BOTTOM HEAD MOTOR (RUN CIRCUIT)
- YM2 BOTTOM HEAD MOTOR (START CIRCUIT)
- KM3 TOP HEAD MOTOR (RUN CIRCUIT)
- DM3 TOP HEAD MOTOR (RUN CIRCUIT)
- YM3 TOP HEAD MOTOR (START CIRCUIT)
- KM4 LEFT SIDE HEAD MOTOR (RUN CIRCUIT)
- DM4 LEFT SIDE HEAD MOTOR (RUN CIRCUIT)
- YM4 LEFT SIDE HEAD MOTOR (START CIRCUIT)
- KM5 RIGHT SIDE HEAD MOTOR (RUN CIRCUIT)
- DM5 RIGHT SIDE HEAD MOTOR (RUN CIRCUIT)
- YM5 RIGHT SIDE HEAD MOTOR (START CIRCUIT)
- 1KM6 TABLE UP CONTACTOR
- 2KM6 TABLE DOWN CONTACTOR
- KM7 GANG SAW (RUN CIRCUIT)
- DM7 GANG SAW (RUN CIRCUIT)
- YM7 GANG SAW (START CIRCUIT)