

EUMABOIS 12-132-34 PORTUGAL

MF-630

PLANER/MATCHER/MOULDERS

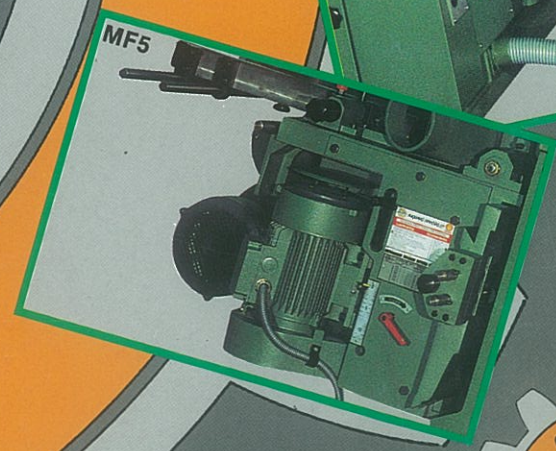
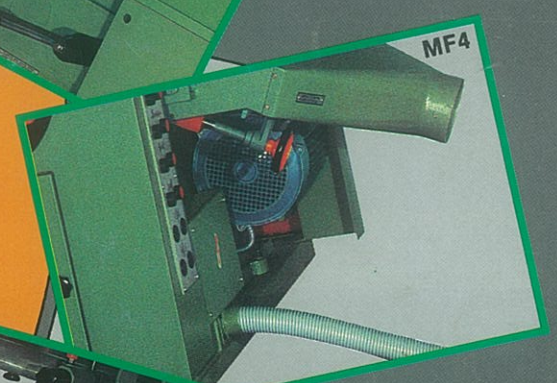
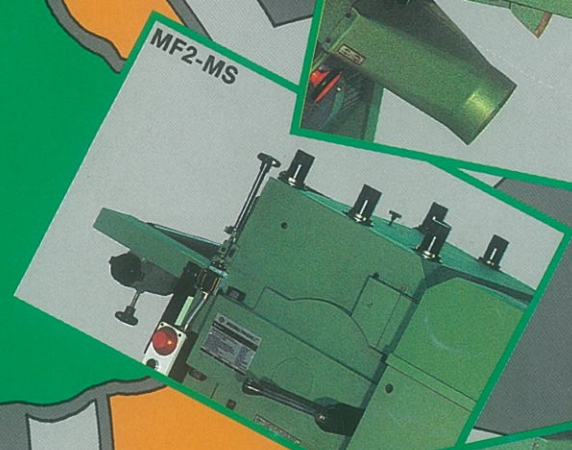
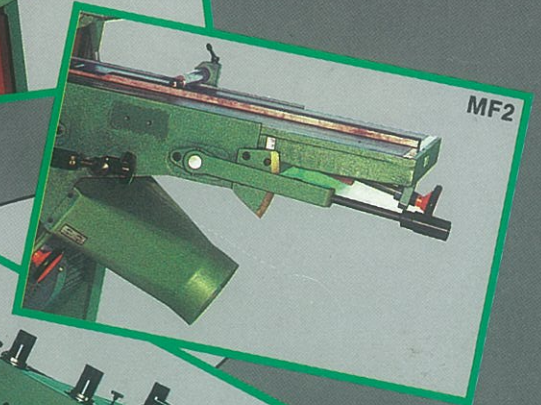
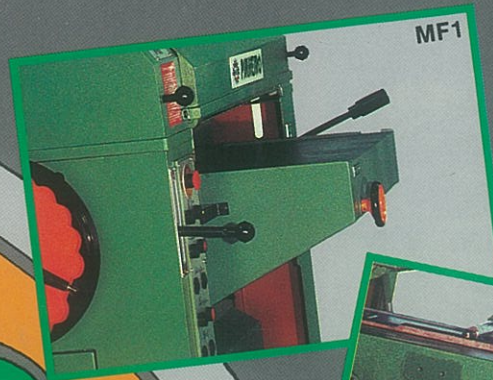

MF1 SINGLE SURFACER PLANER AND MOULDER

This 630 x 200 mm (24" x 8") top head planer is about the most rugged single surfacer available today and has been designed to handle daily production very economically.



Anti-kickback fingers.

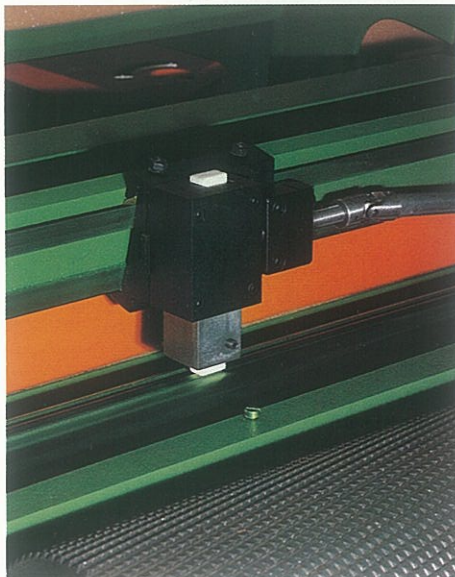

Jointer on top cutterhead.



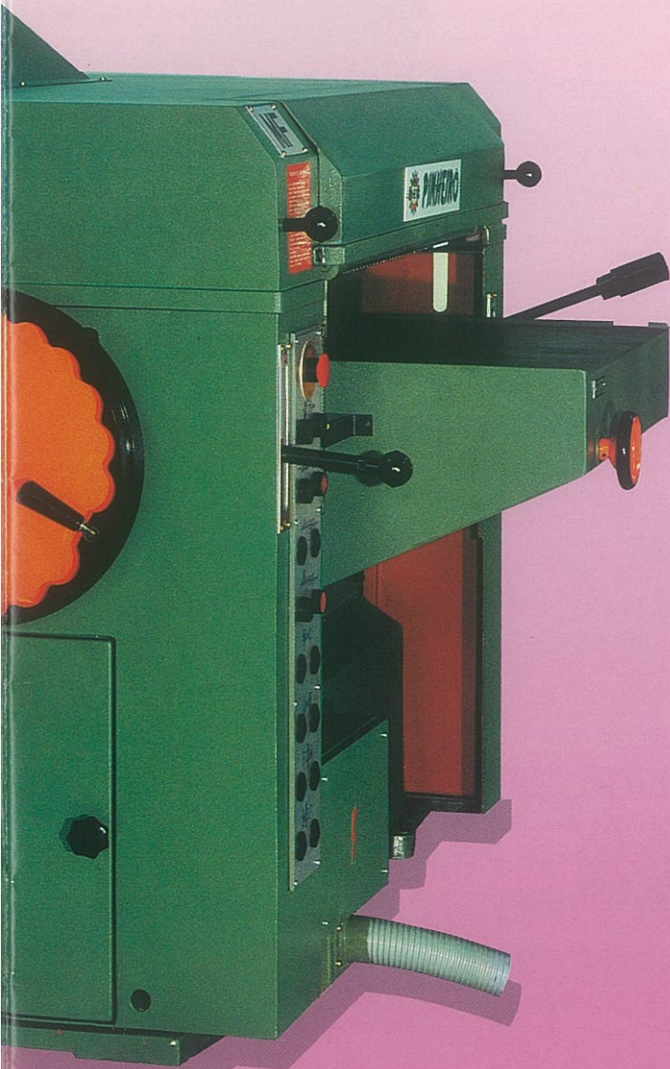
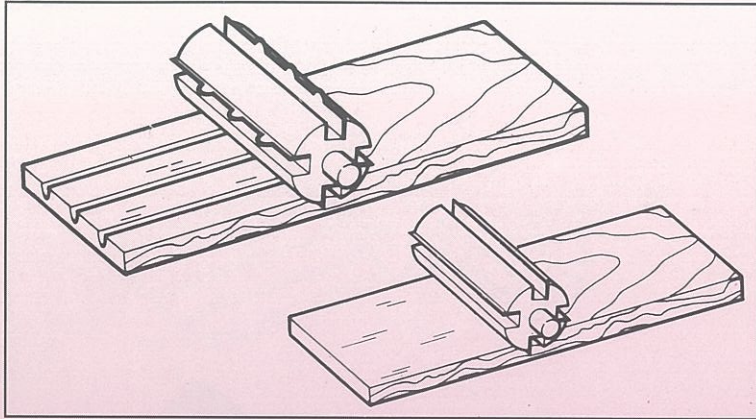

Timer.

MF2 DOUBLE SURFACER PLANER AND MOULDER

This very popular model has a bottom jointing head and is today performing in a very wide variety of both hardwood and softwood operations, and can be expanded into a 4 or 5 head PLANNER/MOULDER at any time.

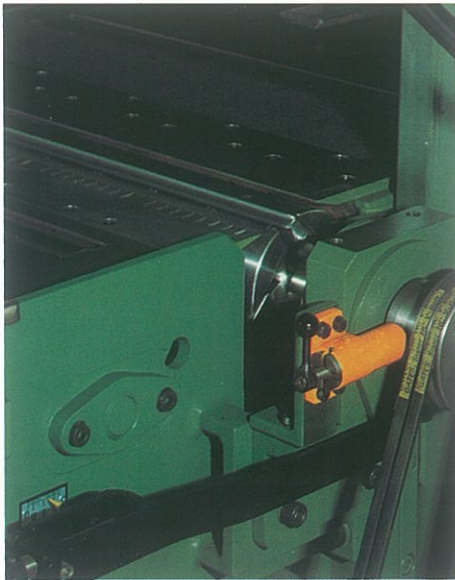

Bottom cutterhead with height adjustment and locking device.

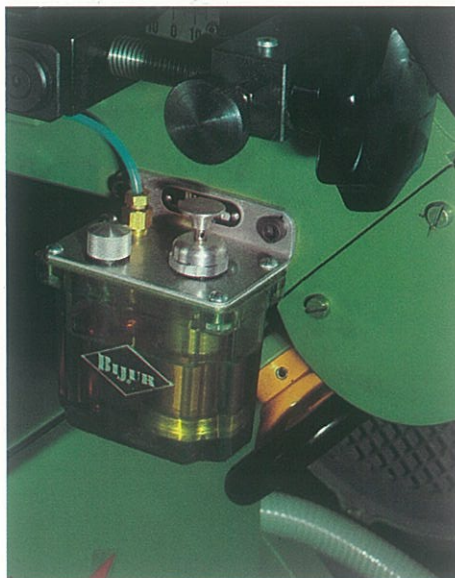

Centralized lubrication of the table screws and guides.

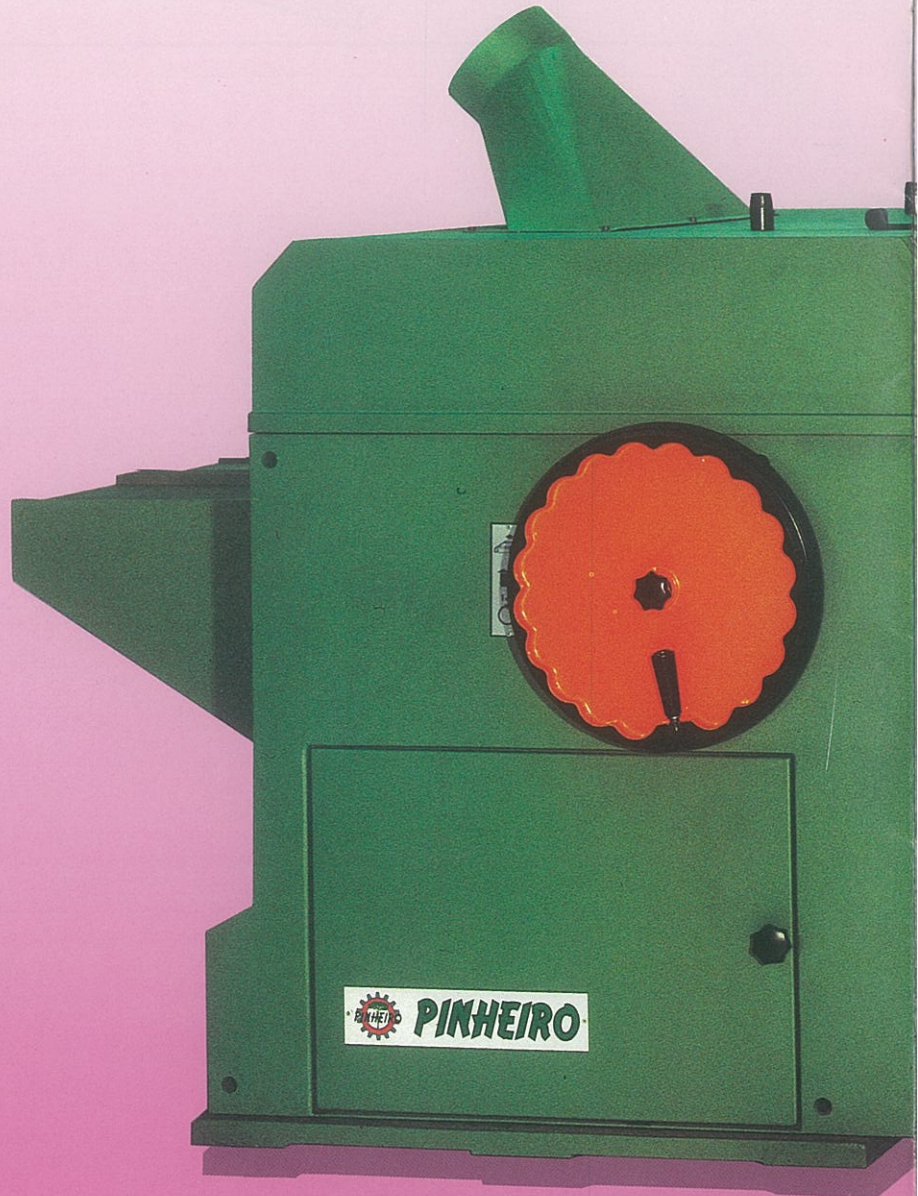

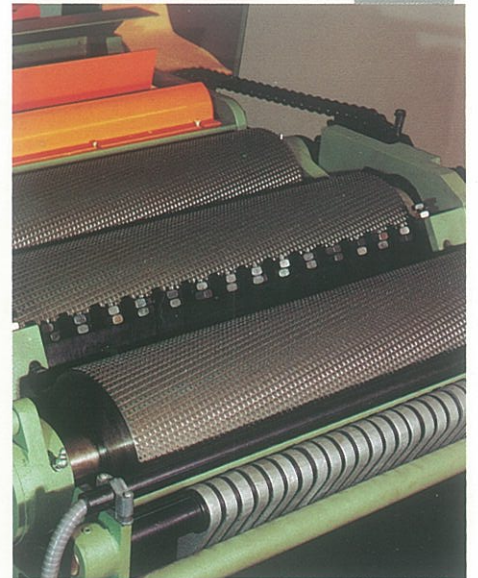
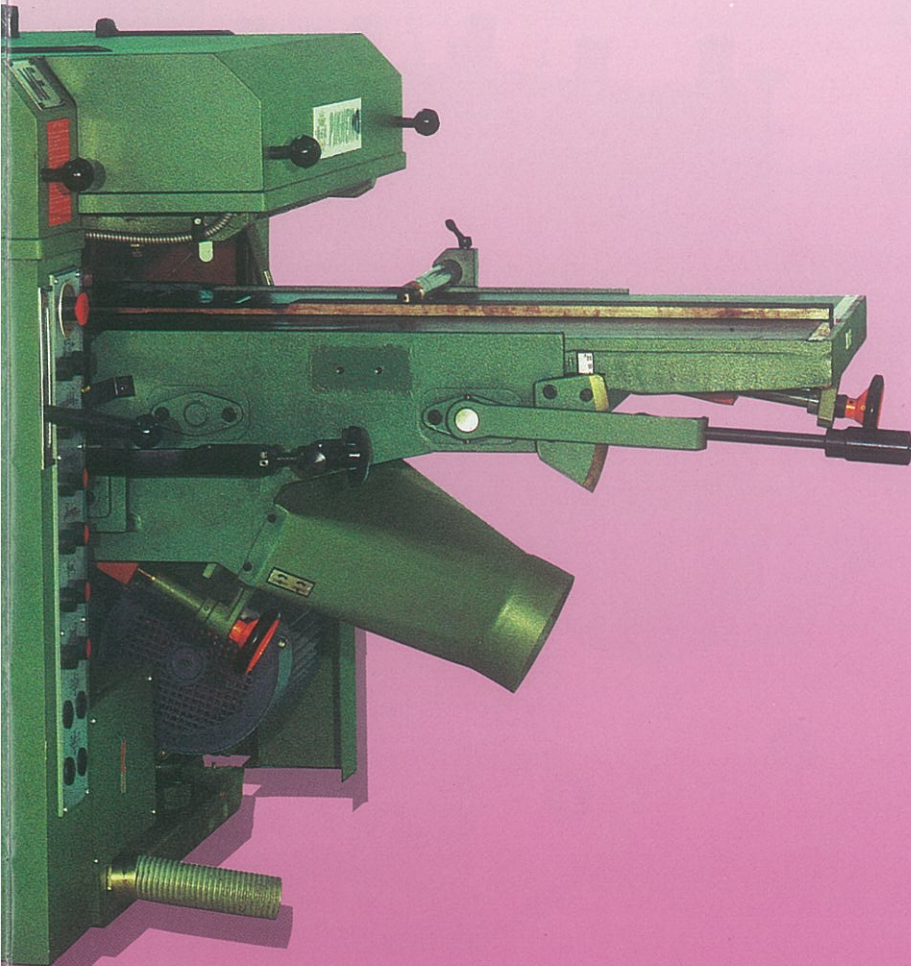
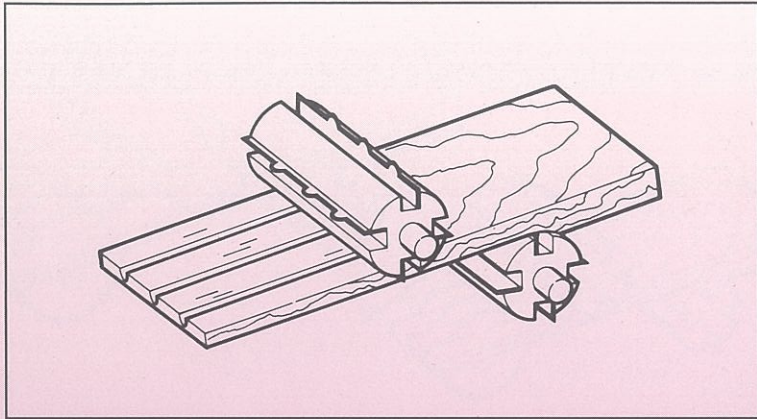

Top infeed rolls of big diameter and sectional holddown.

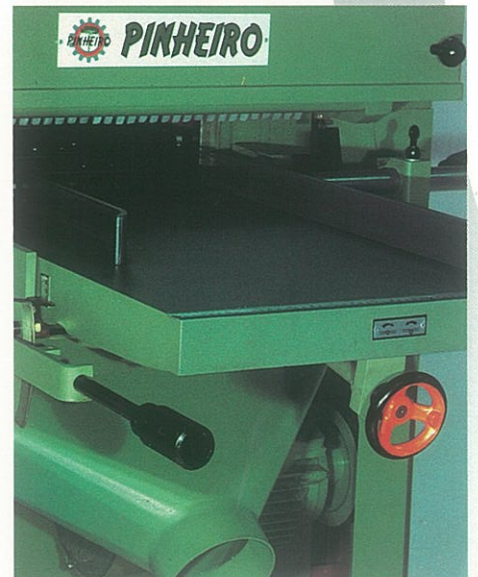

Infeed table and bottom feed rolls height adjustments.

MF2-MS DOUBLE SURFACER/GANG SAW

This 630 x 105 mm (24" x 4") combination machine can be efficiently operated as a single or double surfacer planer and moulder or as planer/moulder/gang saw. The wide width capacity allows for different bays to be set up so that multiple products to be run simultaneously.



Gang rip saw.

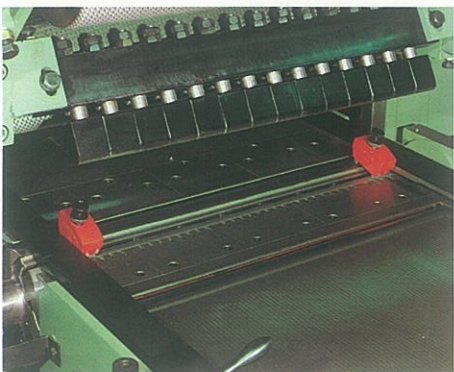

Magnetic knives setting device.

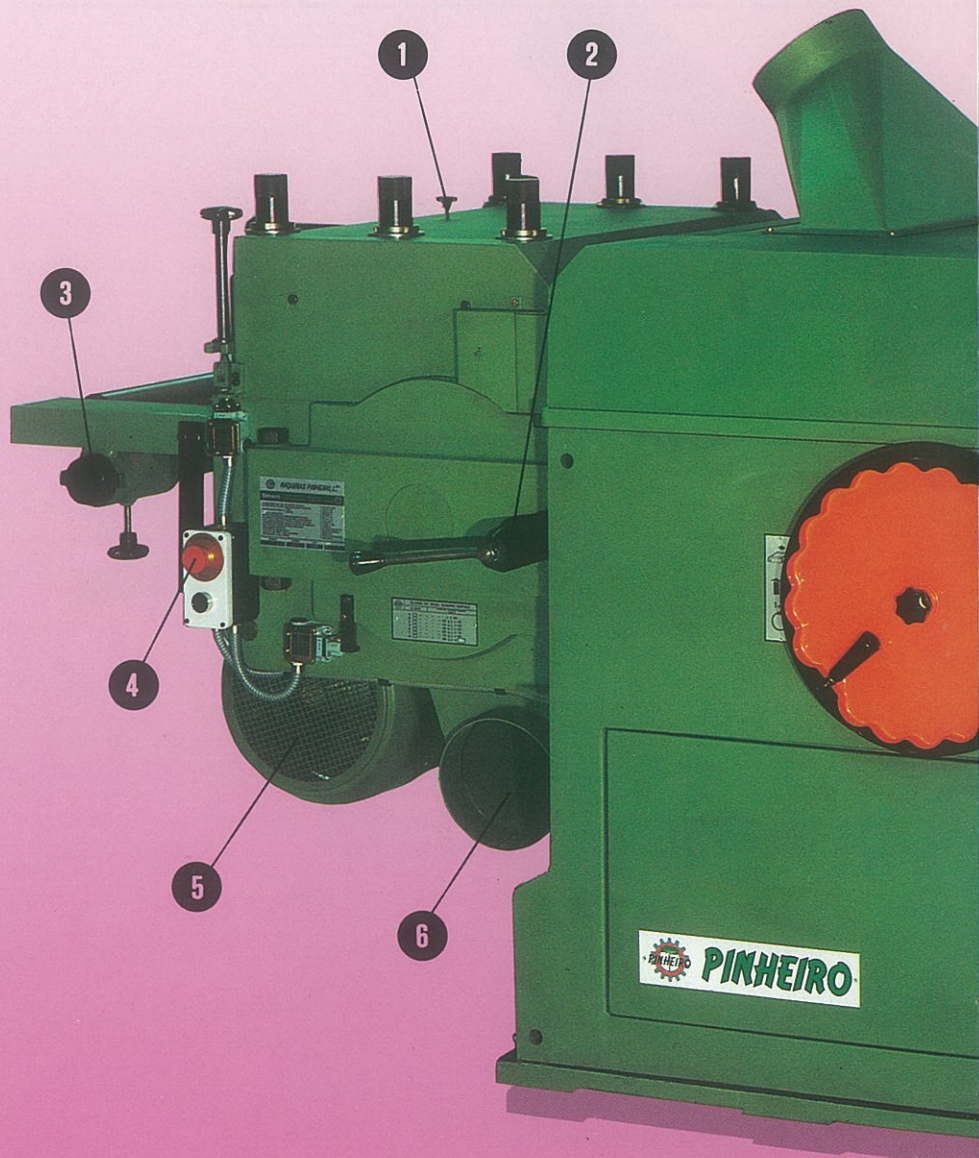

- | | |
|---------------------------------|---------------------------|
| 1) Retractable top feed system. | 4) Emergency stop button. |
| 2) Saw arbor access door. | 5) Motor saw arbor. |
| 3) Saw sleeve work station. | |

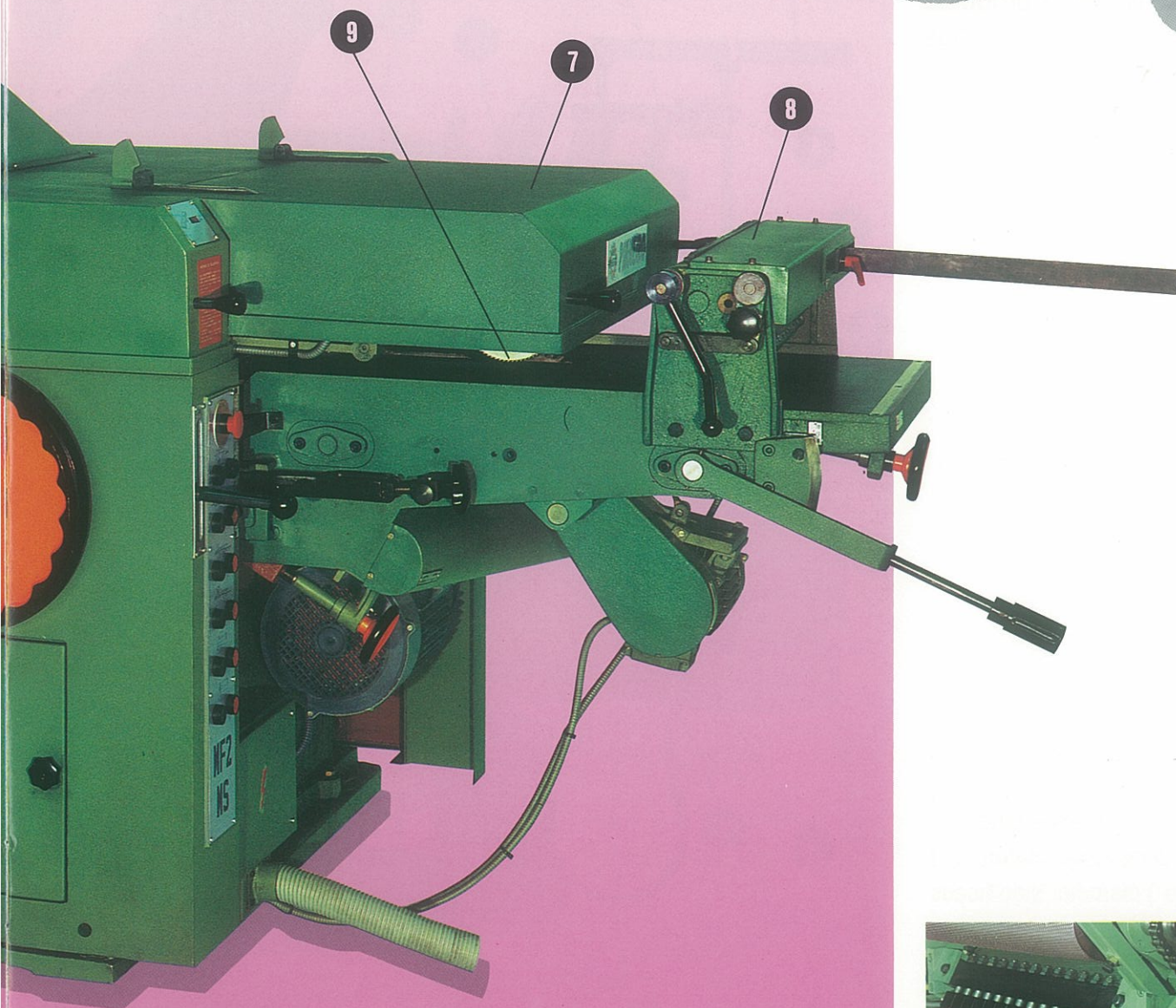
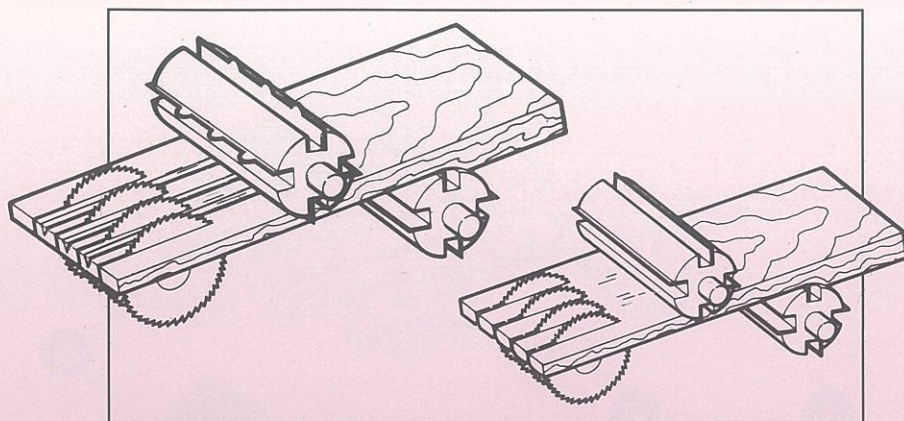

6) Dust hood for gang rip saw.
7) Hinged top cover.

8) 2 sets anti Kickback fingers.
9) Pre-scoring system (option 59).

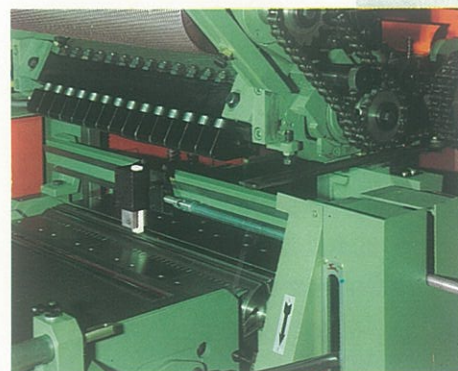

Jointer on bottom cutterhead.

MF4 PLANER/MATCHER MOULDER

This extremely flexible four head machine can effectively handle single and double surfacing production runs as well as produce a tremendous variety of products ranging from quality mouldings to log cabins and from 520 mm (20") wide flooring to timber sizing.

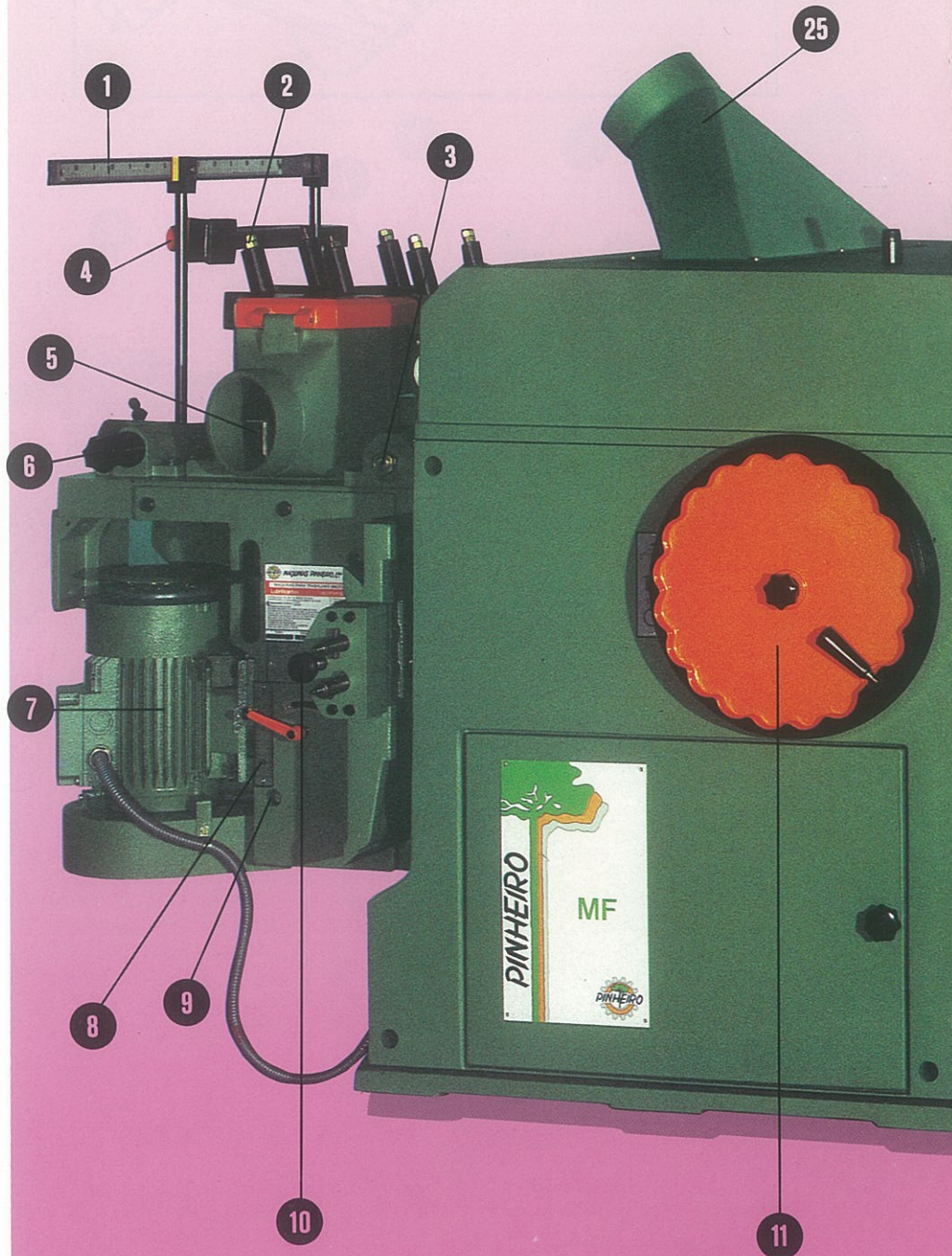

- 1) Scale for finished width.
- 2) Removable outfeed holddown.
- 3) Spring loaded left fence base.
- 4) Rear emergency stop button.
- 5) 150 mm (6") diameter side heads dust hood.
- 6) Rear fence adjusting device and lock.
- 7) 7,5 HP (9 HP / 60 HZ) sidehead motors.
- 8) Vertical sidehead adjustment scale.
- 9) Sidehead locking device.
- 10) Sideheads lateral adjusters.
- 11) Table raising and lowering fine control.
- 12) High and low range gear selector.
- 13) 2nd and 3th bottom feed roll adjuster.

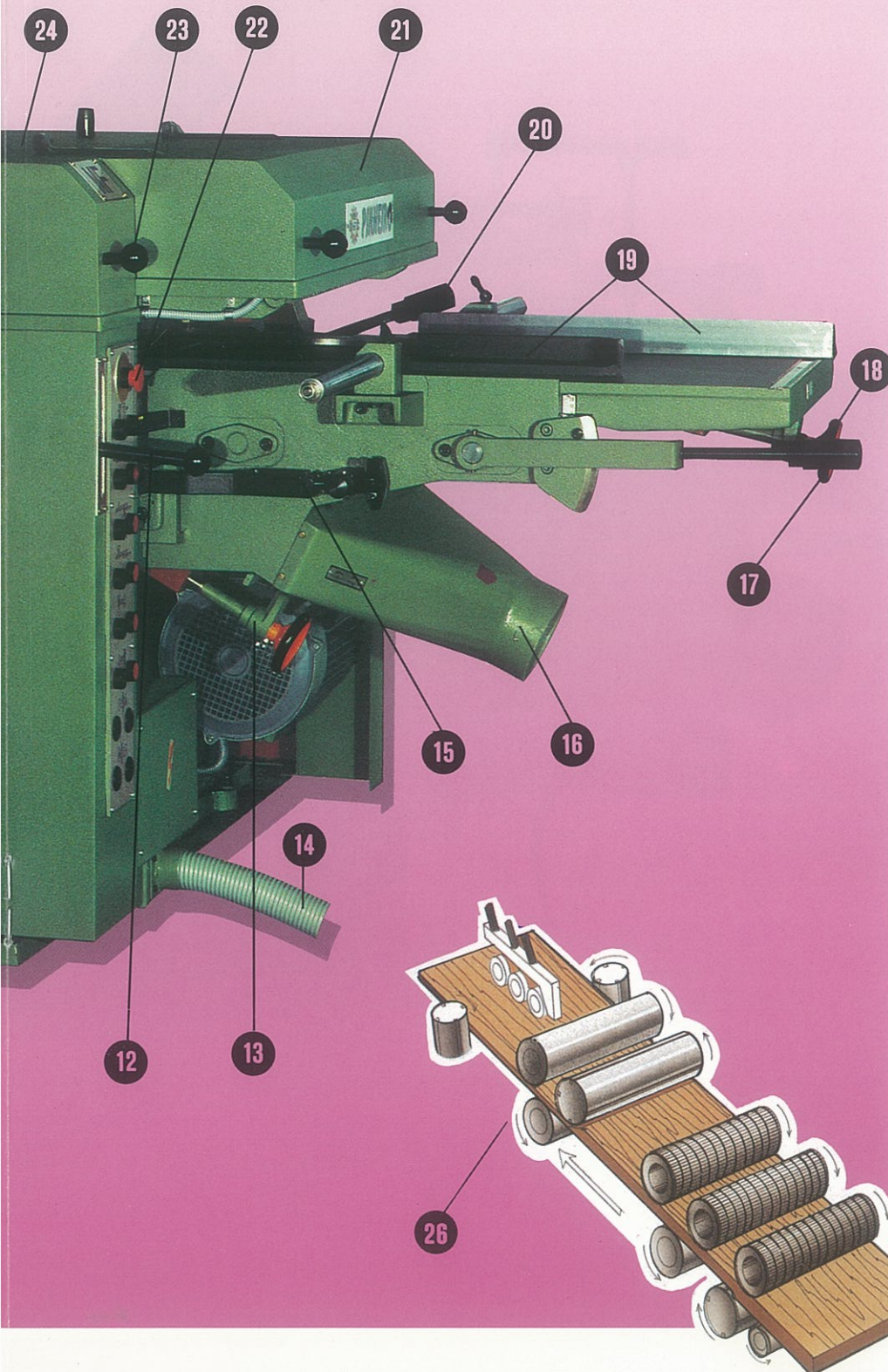
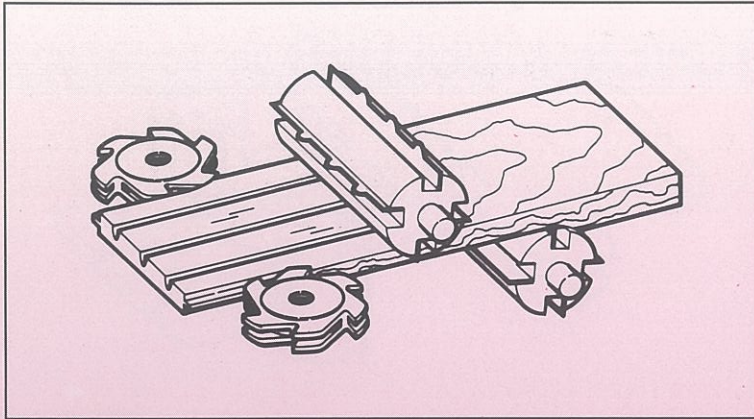

- 14) Electrical cord.
- 15) Bottom cutterhead vertical adjuster.
- 16) 150 mm (7") diameter bottom dust hood.
- 17) Control and gauge to regulate amount of material removed by bottom cutterhead.
- 18) 1st bottom feed roll adjuster.
- 19) Left and right adjustable fence systems.
- 20) Vari-drive control.
- 21) 1st feed roll access cover.
- 22) Front emergency stop button.
- 23) Lifting handles for top cover.
- 24) Hinged top cover.
- 25) 180 mm (8") diameter top dust hood.
- 26) Illustration of feed rolls, outfeed holddowns and cutterheads.

MF5 PLANER/MATCHER/MOULDER

This unit is simply the standard MF4 model with a rear bottom profiler and has been engineered to produce an even wider range of quality wood products and offers the owner/operator the greatest opportunity to efficiently serve both the domestic and foreign markets.

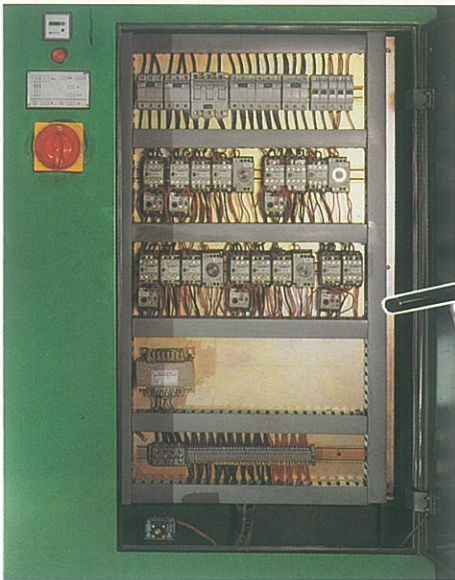

Complete electrical entrance.



5th spindle.

